

Rated Voltage : 12V

Safety Approval

Operating Temp : 10~70°C



Protection : Auto-Restart /Impedance



Material : Housing Plastic (UL : 94V-0)
Impeller Plastic (UL : 94V-0)

Weight : 34g

AIR FLOW-AIR PRESSURE(PERFORMANCE CURVES)
AIR PRESSURE(mmH₂O)

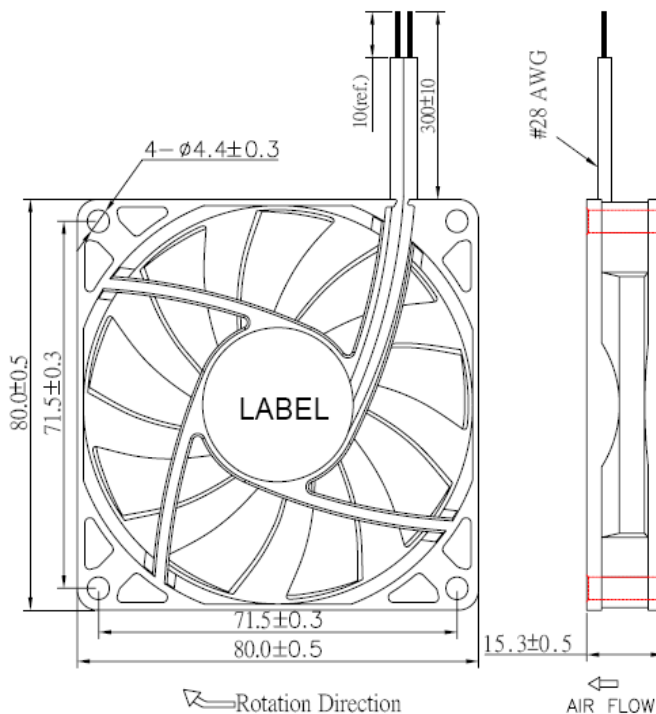
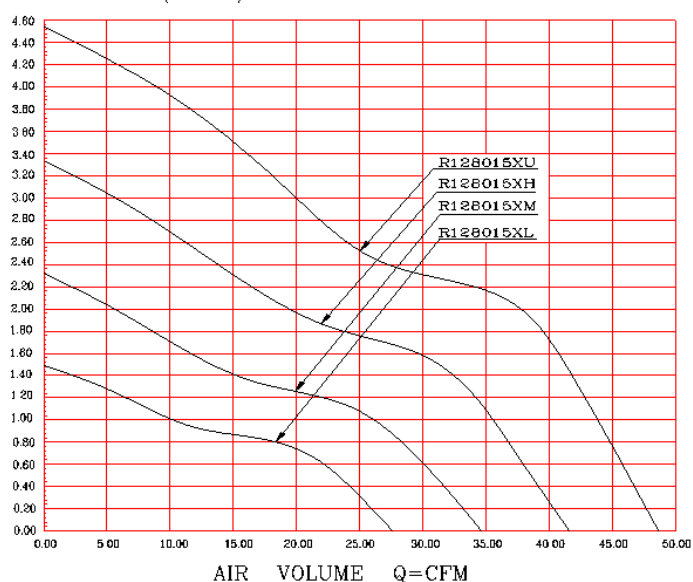

Series	Bearing (*)	Rated Voltage (V)	Rated Current (Amp)	Input Power (W)	Rated Speed (rpm)	Air Flow		Static Pressure (mmH ₂ O)	Noise dB(A)
						(CFM)	m ³ /min		
R128015XL	▲●	12	0.19	2.28	2400	27.89	0.79	1.49	26.30
R128015XM	▲●	12	0.25	3.00	3000	34.86	0.99	2.32	32.10
R128015XH	▲●	12	0.32	3.84	3600	41.84	1.19	3.34	37.70
R128015XU	▲●	12	0.50	6.00	4200	48.81	1.38	4.55	42.00

*Bearing Type : ○ Sleeve ▲EBR ●2 Ball

*Noise measured at the distance of one meter from the axis of intake.

*The latest version would be as per the standard issued by REGO only.